



CORNELL UNIVERSITY
AUTONOMOUS
UNDERWATER VEHICLE
SPONSORSHIP 2024

Research.

Design.

Build.

Win.

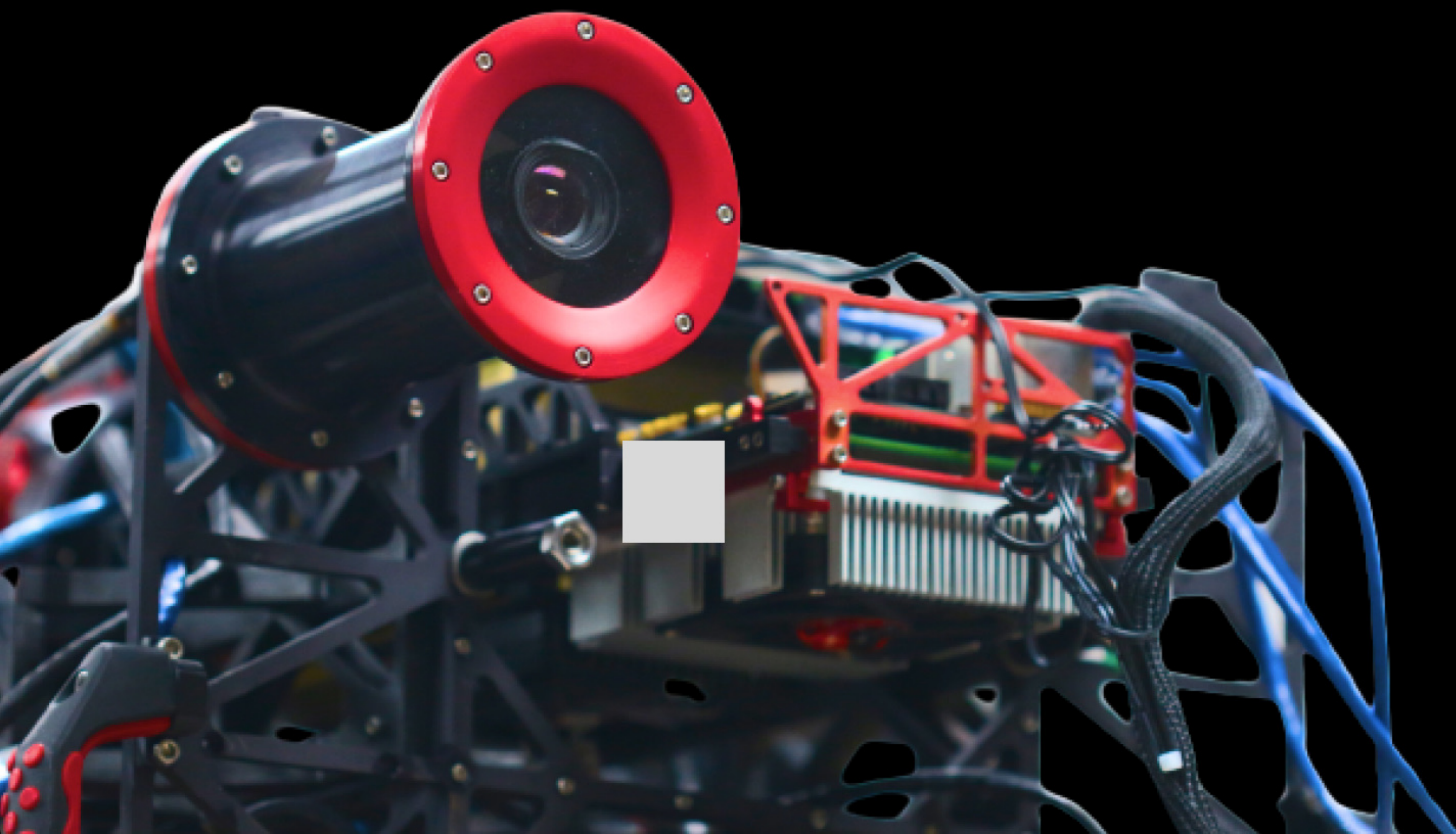
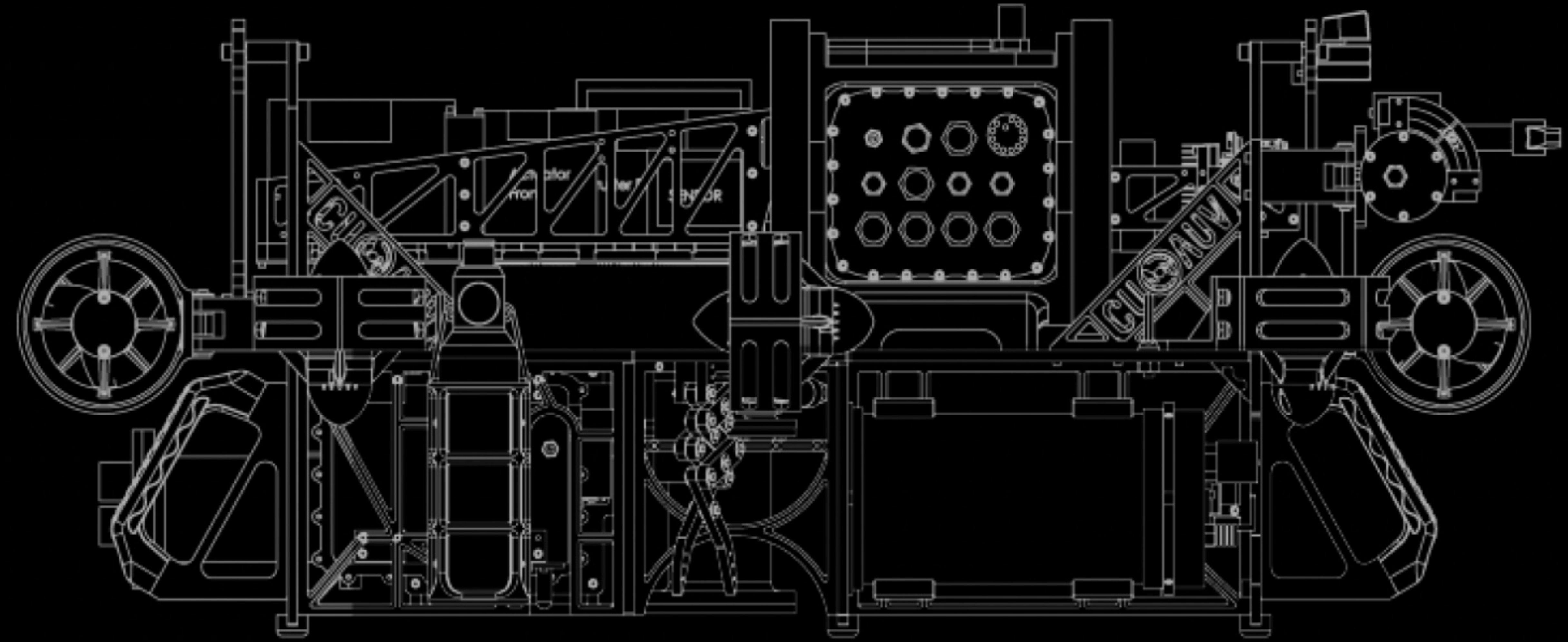

We are a team of students exploring the cutting edge of unmanned underwater vehicle technology.

CUAUV designs, builds, programs and tests a completely new autonomous submarine every year to compete in the Association for Unmanned Vehicle Systems International (AUVSI) RoboSub competition.

CUAUV is entirely undergraduate-run, consisting of over 50 students spanning numerous academic disciplines. The team offers a holistic engineering experience developing new and innovative technology, and students lead the entire design, manufacturing, testing, and revision cycle. As a seven-time RoboSub champion, CUAUV embodies a tradition of excellence and continuously pushes the envelope of autonomous underwater vehicle technology.

Our Team

Mechanical Subteam

Uses Solidworks to design and test the custom enclosures, racks, and hydraulic systems for field manipulation. Components are manufactured in house with mills, lathes, and CNC machines to a tolerance of 0.005 inches.

Electrical Subteam

Designs and populates the custom printed circuit boards that distribute power and process signal throughout the vehicles. They also connect software with the rest of the submarine, ensuring efficiency with the vehicle's power, sensor, and mechatronics systems. The team works together to design an electrical system with modular boards able to interface over an integrated backplane.

Software Subteam

Primarily responsible for maintaining our in-house software stack, which is mainly separated into 3 parts—vision, mission, and controls. Our vision code is responsible for detecting mission elements in the pool using the cameras, which our code then uses to plan and execute missions for the sub to navigate through the competition course. In addition, we also create tools for simulation and diagnostics and maintain our own build server.

Business Subteam

Maintains strong partnerships with sponsors, designs and develops team marketing material, manages team finances, and is responsible for graphic design and development of the website. We also work to create outreach events to give back to the Cornell and Ithaca communities.



Polaris Tech Specs

Polaris is the newest sub built during the 2022-2023 academic year, and will be the main sub used for completing competition tasks. The design was focused on control and modularity, maximizing stability and enclosure accessibility.

NEW RACK DESIGN

Polaris's racks are made of lightweight and strong sheet steel. The sheet metal provides structure and protection to the vehicle's printed circuit boards including the backplane, power management, and thruster ESC boards. The racks also feature a tapered design that gives the boards more clearance when installing or removing the pressure vessel hull, which eliminates the potential for damage during assembly.

NEW MANIPULATOR SYSTEM

This year, the manipulator consists of a deployment system and a claw. The manipulator was designed to be much longer than the previous year's designs to ensure that the claw was in the field of view of the Zed down camera to increase the precision and accuracy of the manipulator. Most of the pieces in these designs were made from 6061 T6 Aluminum with most of the pieces either 1/4" or 1/8" thick pieces. Aluminum was chosen because it is strong and lightweight.

UPGRADED TRANSMIT BOARD

The transmit board first receives power from the power distribution board. Given that the board was powered through one of the extra channels from the PD board, namely channel X1, this year's iteration aims to have a dedicated Transmit channel on that board. Once powered, the transmit board outputs an acoustic signal once its write serial value is enabled.

NEW ACTUATORS SYSTEM

While the use of servo motors alone is hardly new to the RoboSub scene, our new actuators system is unique due to its centralization! It allows for effortless swapping when upgrading servos, and features a single point of failure rather than multiple. Each servo drives a hydraulic master cylinder, which is connected by hydraulic lines to an output cylinder somewhere else on the sub.

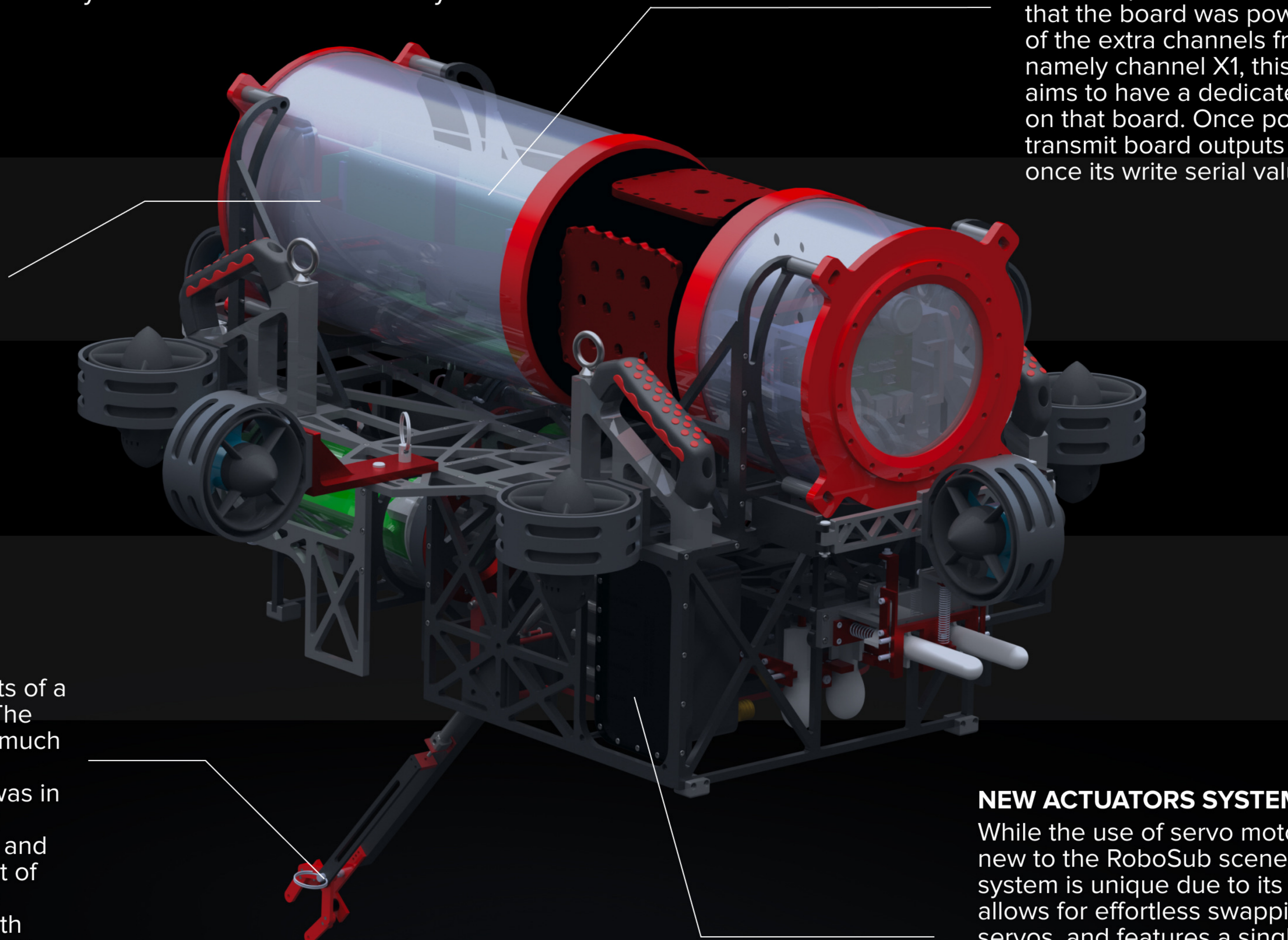

Leviathan Tech Specs

Our secondary sub, Leviathan, is meant to partner with Polaris in completing competition tasks. It is similarly equipped with sensors allowing for pressure, temperature, depth, and acceleration measurement as well as actuators that allow for the use of a manipulator for physical object interaction.

NEW CAMERA ENCLOSURES

The downward camera external enclosure contains UI-6230SE camera and Kowa LM3NCM lens used for detecting targets beneath the vehicle. The new endcap design allows for ease of manufacturing and increased serviceability of the enclosed camera & lens.

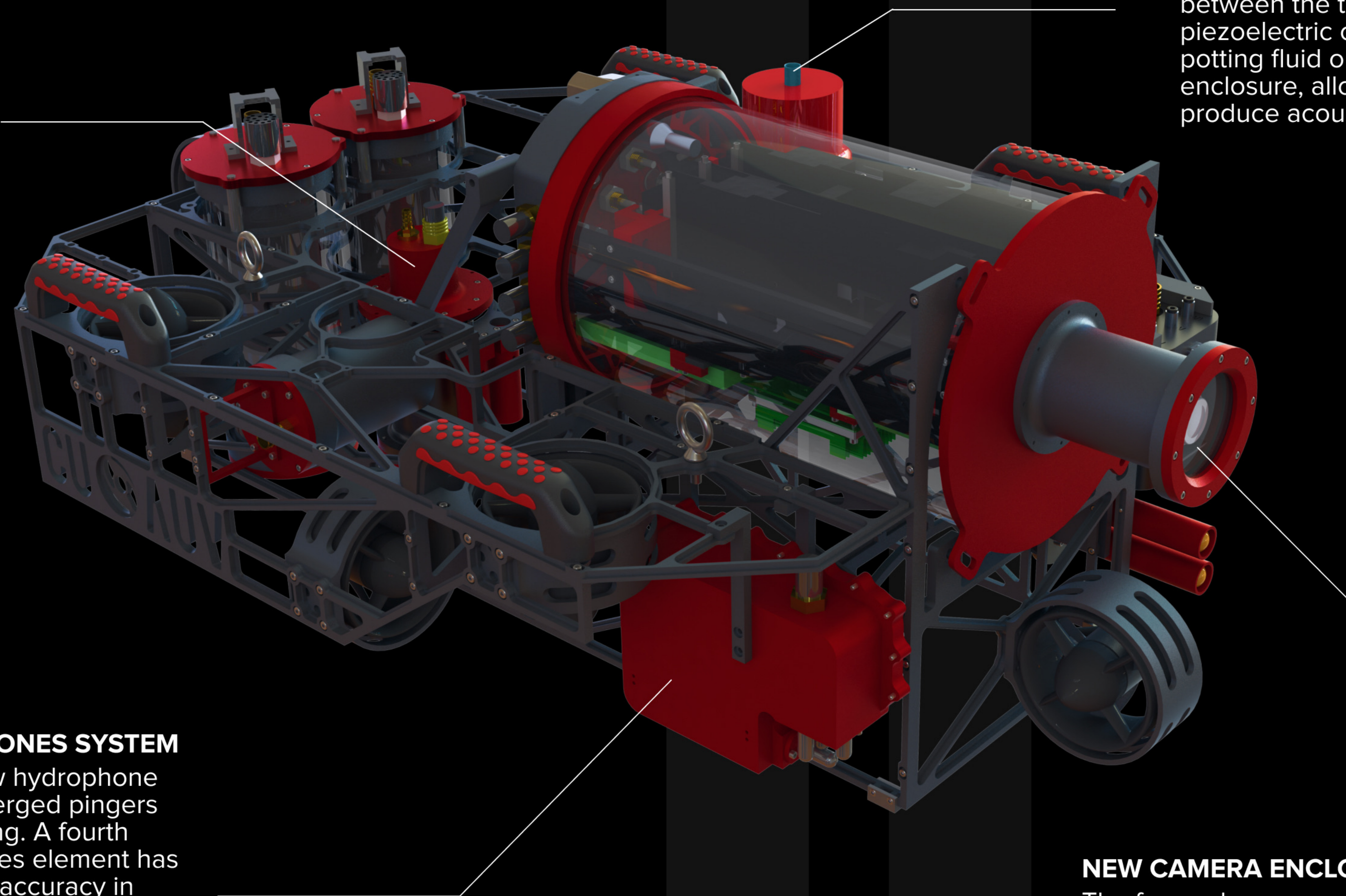

NEW ACOUSTIC TRANSMITTER

Ensuring water-tight connection between the transmit PCB and piezoelectric crystal surrounded by potting fluid on exterior of the enclosure, allowing the AUV to produce acoustic signals.

UPGRADED HYDROPHONES SYSTEM

Leviathan features a new hydrophone systems to detect submerged pingers and determine its heading. A fourth piezoelectric hydrophones element has been added to increase accuracy in triangulating acoustic pressure waves from both the competition pinger and the acoustic transmitter on our other vehicle.

NEW CAMERA ENCLOSURES

The forward camera enclosure houses a UI-5140CP camera and Navitar NMV-4WA lens for forward vision and object detection. The hull (Figure 8) is a cylindrical casing, made of 6061-T6 Aluminum, that protects the camera-lens combination.

Timeline

In the fall, the mechanical and electrical teams spend the majority of the semester designing next year's vehicles while the software team performs training and testing sessions on last year's vehicles. Weekly 5-hour pool tests are held for new members to learn about the old subs.

Team members spend their summer on campus working in the lab, training, and testing for competition. In July, we ship our vehicles to San Diego and fly out to TRANSDEC, a Navy testing pool, to cheer them on as they navigate complicated underwater obstacle courses with no human intervention.

Fall

Spring

Summer

The mechanical and electrical teams fabricate, test and integrate their parts into the new vehicles, while the software team upgrades the software stack for the new designs. Weekly 5-hour pool tests are held for in-water testing and mock competition runs.

Why Sponsor CUAUV?

New Technology

By sponsoring CUAUV, you will support a completely student-led project team at **Cornell University** that is dedicated to pushing the boundaries of autonomous underwater vehicle (AUV) technology.

As we embark on a complete redesign of two submarines this year, your sponsorship will provide us with the extra resources we need to bring our innovative designs to life. Your contribution will enable us to create state-of-the-art AUVs that showcase the latest advancements in engineering, robotics, and automation.

Brand Visibility

We also maintain a **strong social media presence**, reaching a wide audience of tech enthusiasts, students, and industry professionals. By sponsoring our team, you can leverage our social media platforms to showcase how your innovations have played a crucial role in helping us tackle complex engineering challenges. This exposure allows you to **highlight your products and services to a targeted audience**, enhance brand visibility, and reinforce your reputation as a leader in the industry.

Cornell University is also a 501(c)(3) organization, all donations are tax-deductible, providing an additional **charitable** incentive for supporting our team.

Networking

CUAUV has a rich history as a veteran among other RoboSub teams, and our expertise and accomplishments have attracted attention from new teams looking to enter the competition. We would be delighted to **recommend you as a trusted resource** for new teams, helping them acquire the necessary parts and components.

Furthermore, we offer opportunities for you to **connect with talented individuals** in Cornell's esteemed Engineering community through information sessions, professional panels, and mentoring programs. This allows you to establish relationships with upcoming tech talent, gain valuable insights, and even demonstrate new products.

Become a Sponsor

The team depends on the generous support of its sponsors and could not exist without them. To become a member of the CUAUV sponsor group, we request a contribution to help support our endeavors in creating and improving autonomous underwater vehicle technology.

Ways you can
sponsor the team

Monetary donations
Hardware donations
Software donations
Air mileage donations



















Sponsorship Packages

As a sponsor, your company will have access to CUAUV's updated team resume book featuring highly qualified undergraduate students interested in both full-time and internship positions. Your company will also be featured across our website, competition paper, posters, and brochures. Our available packages will be listed in the following two pages.









Plan an **information session** hosted by CUAUV!

CUAUV is a great way for your company to reach out to highly qualified and engaged Cornell students majoring in related engineering fields. Together through our Cornell Engineering Project Team network and our strong, longstanding campus presence, we can help expose students to your employment opportunities and cater to your specific needs to organize and advertise a custom event that will maximize your recruitment efforts..

Sponsorship Packages

	Bronze \$100-\$499	Silver \$500-\$999	Gold \$1,000-\$2,999	Platinum \$3,000+
Company name, logo and website link on the team website				
Opportunity for info-session hosting with team				
Company name on '24 competition paper				
Company logo on '24 competition uniform				
Reduced price + Q&A networking info-session hosting with team				

Sponsorship Packages Cont.

	Bronze \$100-\$499	Silver \$500-\$999	Gold \$1,000-\$2,999	Platinum \$3,000+
Personalized sponsors spotlight on social media				
Opportunity to receive team resume books				
Opportunity to demo new products				
Opportunity to mentor students				
Featured company content on bi-annual newsletter sent to alumni, staff, and other sponsors				

Interested in Sponsorship?

Contact us today!



Address

141 Upson Hall, Cornell University
Ithaca, NY, 14853



Email

cuauvleader@gmail.com



Donate

cuauv.org/sponsors
giving.cornell.edu/give

